

**CUSTOMER APPROVAL**

PRINT: \_\_\_\_\_  
 SIGNATURE: \_\_\_\_\_  
 DATE: \_\_\_\_\_

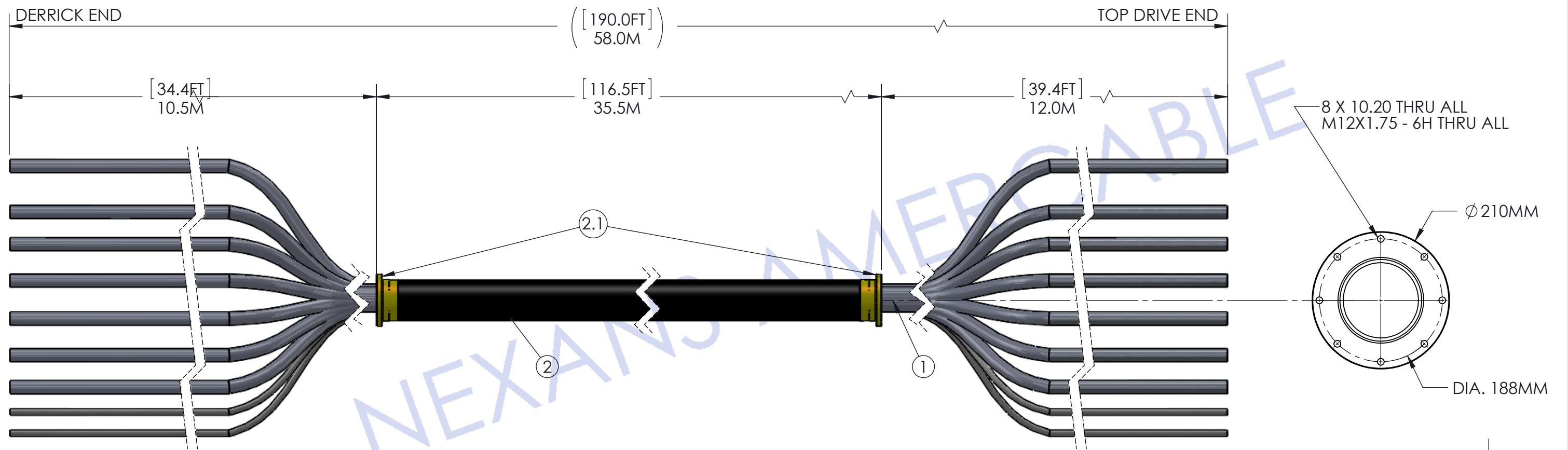

BUNDLE SECTION VIEW

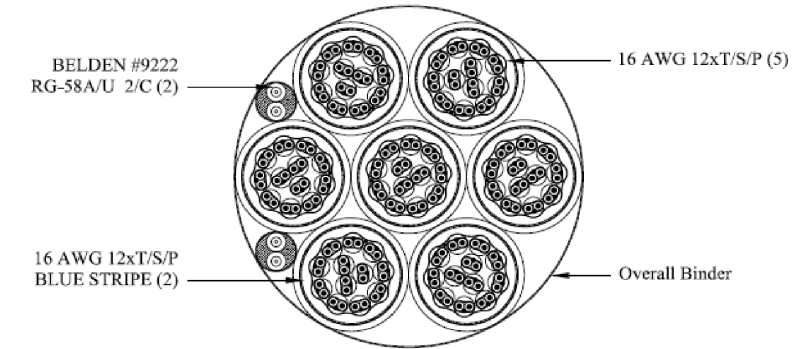

NOTE 1: INSTALL STAINLESS STEEL BRAIDING ON RG-58 CABLES AND COVER IT WITH HEAT SHRINK  
 NOTE 2: BIFURCATE LEADS AT END OF FLANGES

ITEM #	PART NUMBER	DESCRIPTION	UNIT	QTY.
1	374499221	7x 16 AWG 12xT/S/P A&S + 2x BELDEN #9222 RG-58A/U - 2/C INST LOOP	M	58.5
2	HO-T45W116.5NAB	4.5IN PROTECTIVE HOSE, 116.5FT LONG	EA	1
2.1	MP00076-1028	NOV 4.5IN CUSTOM WELD NECK FLANGE	EA	2

NOTES:  
 1. UNLESS NOTED, ALL PARTS SHALL BE PERMANENTLY IDENTIFIED:  
 -MACHINED PARTS: STAMP, ETCH OR ENGRAVE DRAWING NUMBER, REVISION, AND PURCHASE ORDER NUMBER.  
 -WELDMENTS: APPLY DRAWING NUMBER AND REVISION USING LOW STRESS STAMPS.  
 -FABRICATED PARTS AND SHAPES: APPLY DRAWING NUMBER AND REVISION USING PAINT MARKER.  
 2. ALL PRINTS AND COPIES SHALL BE RETURNED UPON JOB COMPLETION UNLESS OTHERWISE SPECIFIED IN WRITING BY AMERCABLE SYSTEMS.

REV	BY	DESCRIPTION	DATE
A	LT	ISSUED FOR APPROVAL.	9/16/2016

COPYRIGHT AMERCABLE SYSTEMS. ALL INFORMATION IN THIS DOCUMENT IS PROPRIETARY AND CONFIDENTIAL, AND SHALL REMAIN THE SOLE PROPERTY OF AMERCABLE SYSTEMS. THIS DOCUMENT SHALL NOT BE USED, COPIED OR REPRODUCED IN WHOLE OR IN PART, NOR SHALL BE REVEALED IN ANY MANNER TO OUTSIDE PARTIES WITHOUT PRIOR WRITTEN PERMISSION FROM AMERCABLE SYSTEMS.

MATERIAL SPECIFICATIONS:  
**N/A**  
 HEAT TREATMENT/SPECIAL PROCESS:  
 ALL DIMENSIONS IN INCHES UNLESS OTHERWISE NOTED  
 TOLERANCES UNLESS OTHERWISE NOTED:  
 -0% + 2% OAL

TITLE: <b>LOOP, OPTION A (GE MOTOR),</b>		
PROJECT: --	DATE: 9/16/2016	SCALE: NTS
DRAFTED: TENG, L.	DATE:	SHEET SIZE: (SLDDRW) B
DFTG CHECK:	DATE:	WEIGHT:
ENG CHECK:	DATE:	PAGE: 1 of 1
PART/DWG NO.: <b>50-3701199</b>	REV.: <b>A</b>	

