

CUSTOMER APPROVAL

PRINT:	
SIGNATURE:	
DATE:	

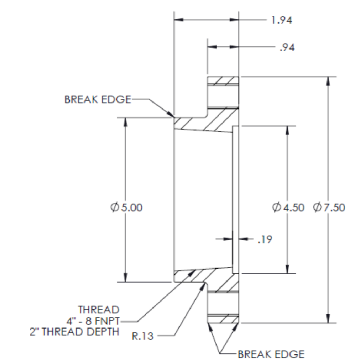
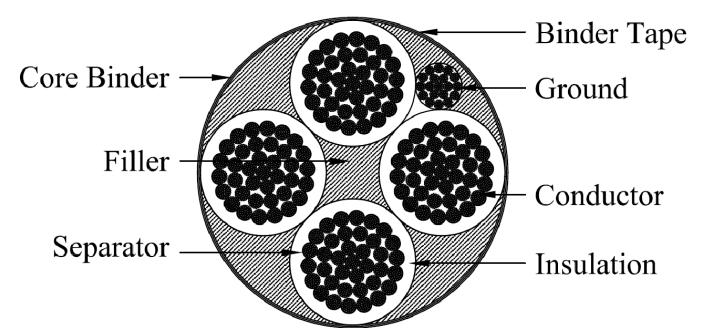
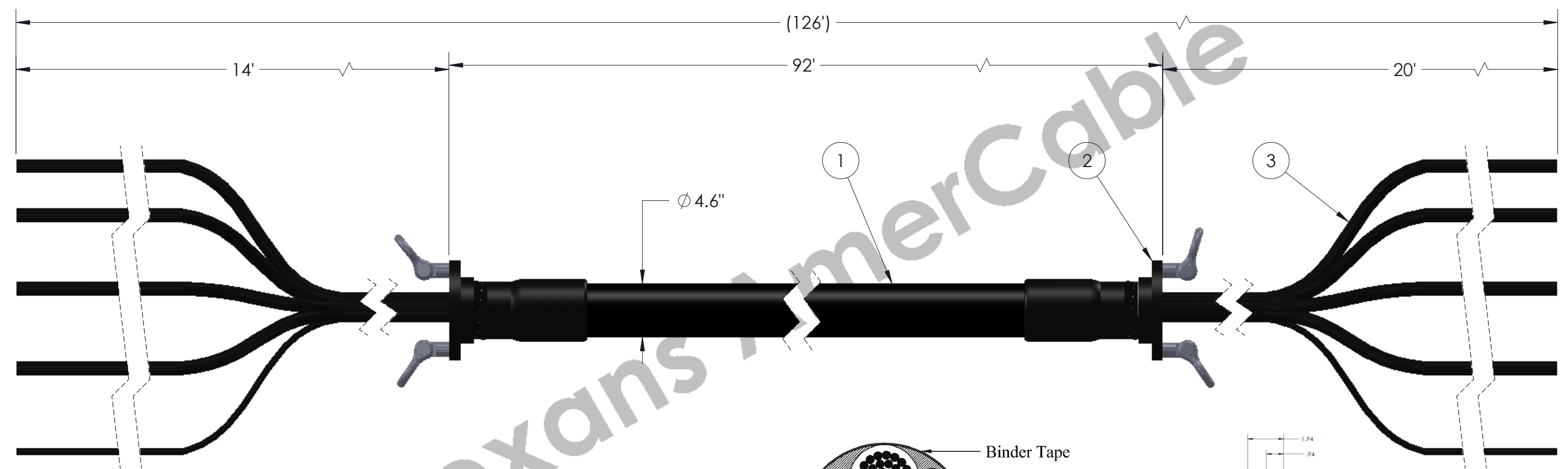

NOTE 1: ALL EXPOSED 646 LEGS (X4) ARE TO BE COVERED WITH SS BRAID AND HEATSHRINK.

NOTE 2: STAMP AMERCABLE P/N ON BOTH FLANGES

NOTE 3: STAMP DERRICK END AND TOP DRIVE END ON CORRESPONDING FLANGES

ITEM NO.	DESCRIPTION	Unit	QTY.
1	4" HOSE, 92FT LONG	EA	1
2	4" NPT FLANGE, 15/16" CUSTOM THICKNESS	EA	2
3	646 X4 + 2/0 DC POWER BUNDLE	FT	126

NOTES:
 1. UNLESS NOTED, ALL PARTS SHALL BE PERMANENTLY IDENTIFIED:
 -MACHINED PARTS: STAMP, ETCH OR ENGRAVE DRAWING NUMBER, REVISION, AND PURCHASE ORDER NUMBER.
 -WELDMENTS: APPLY DRAWING NUMBER AND REVISION USING LOW STRESS STAMPS.
 -FABRICATED PARTS AND SHAPES: APPLY DRAWING NUMBER AND REVISION USING PAINT MARKER.
 2. ALL PRINTS AND COPIES SHALL BE RETURNED UPON JOB COMPLETION UNLESS OTHERWISE SPECIFIED IN WRITING BY AMERCABLE SYSTEMS.

REV	BY	DESCRIPTION	DATE
B	RWW	A: CUSTOMER REQUIRED NOTATIONS	8/3/2016
A	RWW	ISSUED FOR APPROVAL.	7/28/2016

COPYRIGHT AMERCABLE SYSTEMS. ALL INFORMATION IN THIS DOCUMENT IS PROPRIETARY AND CONFIDENTIAL, AND SHALL REMAIN THE SOLE PROPERTY OF AMERCABLE SYSTEMS. THIS DOCUMENT SHALL NOT BE USED, COPIED OR REPRODUCED IN WHOLE OR IN PART, NOR SHALL BE REVEALED IN ANY MANNER TO OUTSIDE PARTIES WITHOUT PRIOR WRITTEN PERMISSION FROM AMERCABLE SYSTEMS.

MATERIAL SPECIFICATIONS:
 HEAT TREATMENT/SPECIAL PROCESS:
 ALL DIMENSIONS IN INCHES UNLESS OTHERWISE NOTED
 TOLERANCES UNLESS OTHERWISE NOTED:
 CABLE BUNDLE:
 -0%, +1% OAL

TITLE: **INNER POWER, 646 X4 + 2/0, 4" X 92' HOSE, 14' TOP DRIVE, 20' DERRICK, NON-CONNECTORIZED**

PROJECT: _____

DRAFTED: WHITE, R. DATE: 7/28/2016 SCALE: NTS

DFTG CHECK: TENG, L. DATE: 7/28/2016 SHEET SIZE: B (SLDDRW)

ENG CHECK: _____ DATE: _____ WEIGHT: _____

PART/DWG NO.: **50-3701292** REV.: **B** PAGE: 1 of 1

